

# **Boston** *Bravo Center*

High Performance Center Channel Speaker

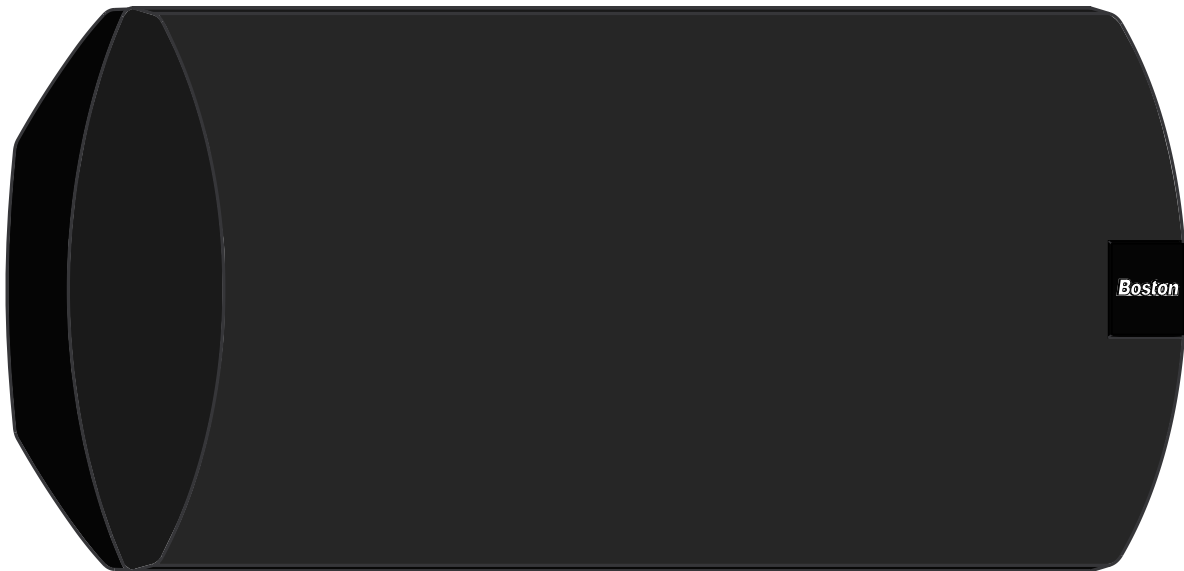

**Boston**  
*Boston Acoustics*

## Specifications

<b>Frequency Response (<math>\pm 3\text{dB}</math>)</b>	80–20,000Hz
<b>Recommended Amplifier Power</b>	15–125 watts
<b>Nominal Impedance</b>	8 ohms
<b>Sensitivity [1 watt (2.83v) at 1m]</b>	89dB
<b>Bass Unit</b>	4½" (115mm) copolymer
<b>Tweeter</b>	1" (25mm) black anodized aluminum dome with AMD
<b>Crossover Frequency</b>	2500Hz
<b>Dimensions (HxWxD)</b>	14¼ x 6½ x 4¼" (362 x 166 x 108mm)
<b>Weight</b>	5.5 lbs. (2.48kg)
<b>Finish</b>	Black textured ABS with matching cloth grille

## Description

The Boston Bravo Center is a compact, high performance center channel loudspeaker which is magnetically shielded with MagnaGuard® for interference-free placement on top of any type of television set. It uses Boston's patented 1-inch aluminum dome VR tweeter with AMD and a 4½-inch woofer. Its built-in, height adjustable rear stand allows it to be safely placed on top of any type of television set regardless how wide the top surface is or how much it angles.

Setting up the Boston Bravo Center on any television set is as simple as loosening the thumbwheel on the adjustable rear stand and then sliding the rear leg up or down to accommodate the top surface of your television. This adjustable rear stand can also be used to safely angle the Boston Bravo Center to compensate for the height of the television set in relation to the listening position. You can also use the Boston CRB swivel bracket to wall mount the Boston Bravo Center. The CRB easily attaches to the two compatible screw holes located above the sliding stand on the rear.

By virtue of its patented VR tweeter, the Boston Bravo Center is an economical and appropriate choice as a center channel speaker for any Boston system using similarly equipped main and rear channel speakers: VR-M50, 60, 80, 90, and VR-MX; VR940, 950, 965, 975; MR90x, and 100x. However, since it shares the Boston Sound™ with all other Boston speakers, the Boston Bravo Center can be used successfully as a center channel speaker with any Boston main and surround speakers. The Boston Bravo Center can also be used in conjunction with any of today's widely available quality loudspeaker brands.

An ideal home theater application would be to use the Boston Bravo Center in conjunction with four standard Boston Bravos. When four are placed vertically in the corners of a room, the standard Boston Bravo creates an unusually wide listening window, providing true stereo or surround sound reproduction over the broadest possible area. Add the Boston Bravo Center and a Boston powered subwoofer and you have a compact and powerful, yet unobtrusive home theater/surround sound system.

## How to Connect Your Speaker

Correctly wiring your Boston Bravo Center is important for achieving the best sound quality. Wiring should take just a few minutes, but it's important to do it carefully, since incorrect wiring (such as reversed connections) can result in a poor soundstage and poor bass.

We recommend 18-gauge wire or thicker for runs up to 15 feet (4.5m), and 16-gauge wire or thicker for longer runs. Separate the first few inches of the wire conductors. Strip off 1/2" (12mm) of insulation from the ends of each speaker wire to expose the two conductors and tightly twist the wire strands.

**WARNING:** To prevent electrical shock hazard, always switch off the amplifier or receiver when making connections to the speaker.

When making all connections, be sure to connect the + (red) on the speaker to the + (red) on the amplifier, and the - (black) on the speaker to the - (black) on the amplifier.

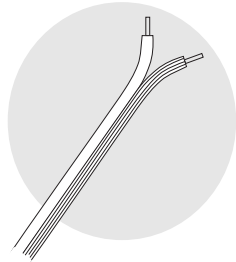

**IMPORTANT:** Typically, one side of the wire is smooth. Connect this side to the - (black) connection. The other side has a rib or stripe. Connect this to the + (red) connection.

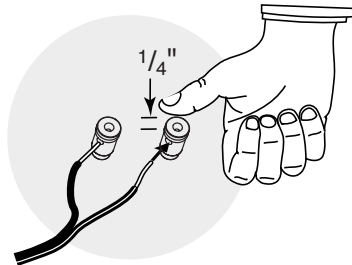

**Using the spring terminal posts:** The spring terminal posts permit easy connection to banana plugs, spade lugs, and bare wire.

Push the the top of the terminal down by approximately 1/4-inch, exposing the hole. Insert the wire in the hole and release the terminal.

## Checking the Speaker Connections

It is important that your speaker is hooked up with similar polarity or "in phase". A simple listening test will tell you if your speaker is connected properly. Reverse the connections while listening to music with your amplifier set to MONO. You'll hear a dramatic change in sound. The connection that yields the fuller bass and louder sound is correct.

## Connecting the Boston Bravo Center to Your Amplifier or Receiver

1. Connect the speaker terminals to the amplifier speaker outputs.
2. When making all connections, be sure to connect + to + and - to - .
3. If you are using your Boston Bravo Center with a Dolby Digital® reciever, set the center channel's bass managment to SMALL in the reciever's setup menu. This will divert very low frequencies away from the center channel to the main speakers and/or subwoofer.

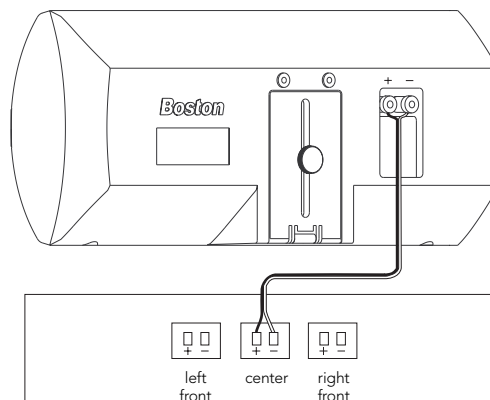

surround sound receiver/amplifier

## Configuring the Boston Bravo Center to Your Setup

The Boston Bravo Center can be configured to accommodate any style of television and home theater arrangement. Take a minute to study the type of television that you have in order to determine which of the following configurations you should use.

### Flat Top Placement

This is the simplest way to configure the speaker and should be used wherever possible. If you are placing the Boston Bravo Center on top of a rear projection TV or one with a large flat top surface (six inches or more in depth), then you can use it just the way it comes out of the box. Use the four self-adhesive rubber feet (provided) to protect the TV's finish and reduce vibration. Peel off and apply a foot to each semi-circular pad located underneath the two front corners of the housing as shown. Apply the other two feet to the outermost corners of the rear support section on either side of the rotating mounting pad as shown. Alternatively, you may wish to secure the speaker to its surface by eliminating the rear feet and using the self-adhesive, pre-installed hook-and-loop strip instead (see illustration below).

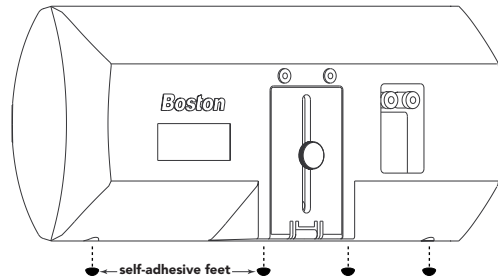

### Angled Top Placement

If your TV has a shallow top (less than six inches in depth) and angles downward in the back, then you should use the sliding rear stand to secure the back half of the speaker. First apply the two front rubber feet as shown above (do not apply the rear feet). Loosen the knurled knob, move the slide down and flip up the rotating mounting pad. With the speaker centered and in the position that you want it to stay in, move the slide down until the mounting pad contacts the angled surface of the TV. Pull off the paper backing from the pre-attached, self-adhesive hook-and-loop strip and stick the mounting pad on the TV. Press down on the mounting pad to ensure that the two hook-and-loop halves are locked. Adjust the speaker to its upright position and tighten the knob firmly. If you need to move the slide down more than one inch, then remove the knob from the upper hole and screw it into the lower hole as shown to the left. This will centralize the contact point of the slide and prevent any rattling that may occur at very loud volumes. It will also double the adjustment depth to three inches.

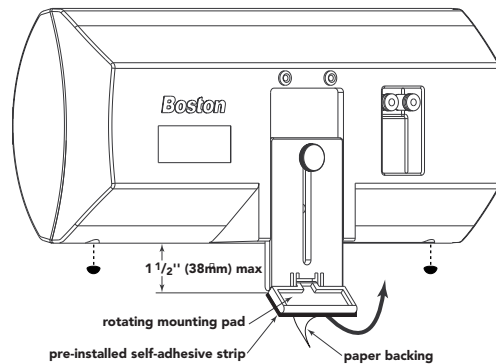
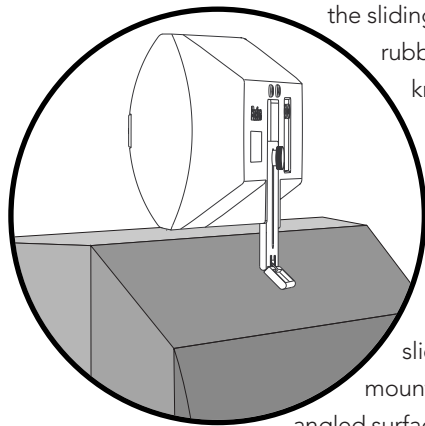

Adjust the speaker to its upright position and tighten the knob firmly. If you need to move the slide down more than one inch, then remove the knob from the upper hole and screw it into the lower hole as shown to the left. This will centralize the contact point of the slide and prevent any rattling that may occur at very loud volumes. It will also double the adjustment depth to three inches.

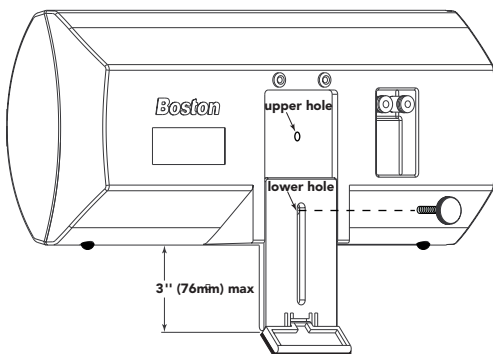

## Configuring the Boston Bravo Center to Your Setup (con't)

### Wall Mounting

You can also mount the Boston Bravo Center to the wall above the TV. To do so, you will need to purchase the optional Boston CRB swivel bracket. The CRB will mount to the rear of the speaker using the two attachment holes shown to the right. Refer to the instruction manual that comes with the CRB

bracket for further installation information. You can purchase the Boston CRB bracket from your Boston Acoustics dealer or use the enclosed order form to purchase it directly from us. We recommend that you purchase the CRB bracket in black to match your black Boston Bravo Center speaker.

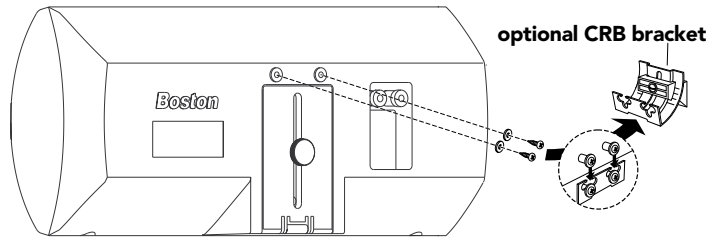

### Room Placement

When setting up the Boston Bravo Center to suit your television, try to position it as close as possible to the center of the screen. The Boston Bravo Center channel is magnetically shielded with MagnaGuard® and can be placed directly on top of any type of television and not affect or interfere with the picture in any way. It is not necessary to angle the speaker to face the listeners, although the adjustable rear stand will allow for this (with the hook-and-loop strip attached to the TV). Shown is a typical Boston Bravo home theater setup consisting of the Boston Bravo Center, two corner mounted standard Bravos in the front and two side wall mounted standard Bravos in the rear as surrounds. A Boston powered subwoofer completes the home theater experience.

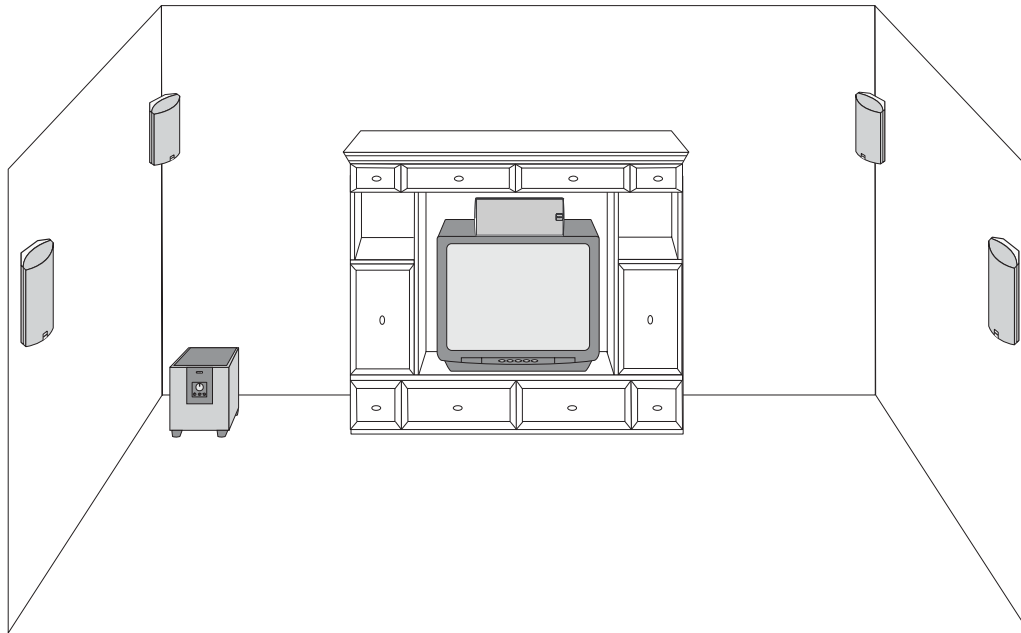

### Listening Levels and Power Handling

The listed power recommendations in the Specifications section assume you will operate your system in a way that will not produce distortion. Even these rugged speakers can be damaged by a modest amplifier if it produces distortion. If you hear a harsh, gritty noise, turn down the volume. Prolonged or repeated operation of your speaker with a distorted signal from the amplifier can cause damage that is not covered by the warranty.

## Limited Warranty

For five years from the date of purchase, Boston Acoustics will repair for the original owner any defect in materials or workmanship that occurs in normal use of this speaker, without charge for parts and labor.

Your responsibilities are to use the system according to the instructions supplied, to provide safe and secure transportation to an authorized Boston Acoustics service representative, and to present proof of purchase in the form of your sales slip when requesting service.

Excluded from this warranty is damage that results from abuse, misuse, accidents, shipping, or repairs or modifications by anyone other than an authorized Boston Acoustics service representative.

*This warranty is void if the serial number has been removed or defaced.*

This warranty gives you specific legal rights, and you may also have other rights which vary from state to state.

## If Service Seems Necessary

First, contact the dealer from whom you purchased the speakers. If that is not possible, write to:

Boston Acoustics, Inc. 300 Jubilee Drive Peabody, MA 01960 U.S.A.

We will promptly advise you of what action to take. If it is necessary to return your speaker to the factory, please ship it prepaid. After it has been repaired, we will return it freight prepaid in the U.S.A. and Canada.

# **Boston**

*Boston Acoustics*

[www.bostonacoustics.com](http://www.bostonacoustics.com)

300 Jubilee Drive  
Peabody, MA 01960 U.S.A.  
978.538.5000

Dolby and Dolby Pro Logic are registered trademarks of Dolby Laboratories Licensing Corporation.

VR and AMD are trademarks and MagnaGuard, PowerVent, Boston, and Boston Acoustics are registered trademarks of Boston Acoustics, Inc.

© 2001 Boston Acoustics, Inc. All rights reserved.  
Specifications subject to change without notice.

042-001476-1